



THE CITY OF
Carmel-by-the-Sea
COMMUNITY PLANNING & BUILDING DEPARTMENT
Administrative Policies & Procedures
Policy No. 2017-##
STORY-POLE POLICY

PURPOSE

To require the installation of story-poles and netting for Design Study/Review applications in order to assist decision makers and the public in evaluating the height, location and extent of proposed development for consistency with local regulations and ordinances.

APPLICABILITY AND TIMING OF INSTALLATION

The installation of story-poles and netting shall be required for residential and commercial design study/review applications that increase floor area or structure height or may otherwise impact privacy or views (i.e. decks and balconies) as outlined below. Installation of story-poles is optional for preliminary project reviews.

Staff-Approved Projects (i.e. Design Study/Review, Track One)

Story-poles and netting shall be installed for all new structures, additions and second-story decks exceeding 120 square feet in size. Story-poles shall be installed prior to the issuance of a Notice of Approval and shall remain in place until the 10 calendar-day appeal period has ended. Height certification is not required. The height of existing on-site structures may be used as a reference point when installing story-poles and netting.

Public Hearing Projects (i.e. Design Study/Review, Track Two)

Story-poles and netting shall be installed at least 10 calendar days prior to the public hearing. The story-poles and netting shall remain in place until final action has been taken on the project and the 10 working-day appeal period has ended. The highest point of the story poles and netting shall be certified by a California licensed surveyor or civil engineer prior to distribution of a Public Notice. The Community Planning & Building Director and/or Planning Commission may require other sections of the story poles be certified as deemed necessary. An "Affidavit of Story-Pole Certification" shall be submitted to the Community Planning & Building Department along with a photograph of the story-poles and netting.

Appeals

If an appeal is filed, the story-poles and netting shall remain in place until the project has been reviewed by the appeal body and the appeal period for that review has ended.

Permit Expiration

If a Design Study/Review approval expires and an application to renew the approval is submitted, the story-poles and netting shall be reinstalled in accordance with the Story-Pole Policy.

WAIVER OF REQUIREMENT

The Director of Community Planning & Building may waive the requirement for story-poles and netting for staff-approved projects only, if it can be seen with certainty that the proposed site/building modifications are not visible from the public way and/or will not have a negative impact on surrounding properties.

REQUIREMENTS

It is the applicant's responsibility to ensure that story-poles and netting are installed consistent with this policy and placed in a manner which accurately depicts project elements including but not limited to height, location, mass, and bulk, and that all trees and/or branches proposed for removal are properly identified.

Materials

Story-poles shall be constructed of metal poles or 2-inch by 4-inch (minimum) lumber. Story-poles shall be braced at the base with supporting beams to ensure they will withstand weather and remain correctly positioned. Netting shall be bright orange construction mesh at least 2-feet wide. The first-story finished floor level shall be demarcated by yellow or pink ribbon.

Identification

Story-poles shall be placed at all outside building corners and along the rooflines of the proposed structure(s). Architectural elements such as chimneys, elevated decks and balconies that extend beyond the footprint of the structure shall also be identified. If trees or branches are proposed for removal, they shall have 1-inch minimum fluorescent pink or red flagging ribbon tied around their most visible portion. *If story-poles, netting and/or flagging ribbons are not installed accurately, staff or the decision-making body may continue the project review until such time that placement has been corrected.*

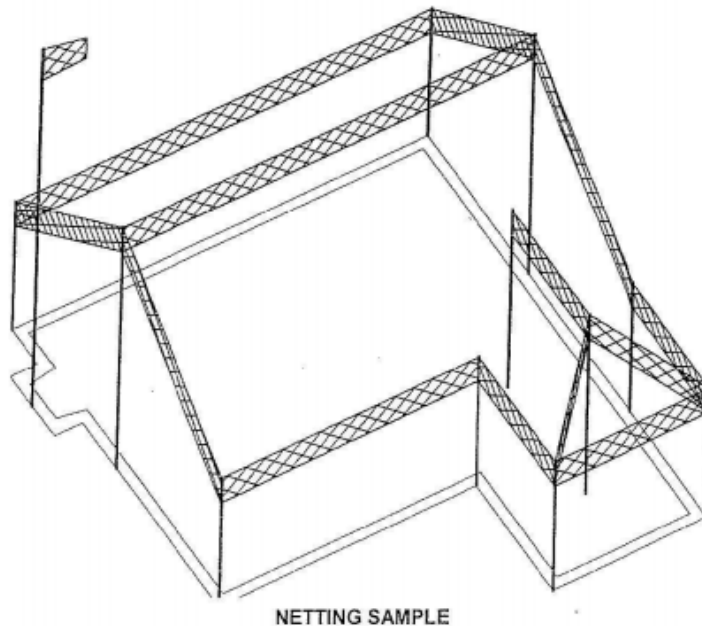

REMOVAL

All story-poles and netting shall be removed at the end of the appeal period following final action on a project.

QUESTIONS

For questions, please contact the Community Planning & Building Department at (831) 620-2010.



AFFIDAVIT OF STORY POLE CERTIFICATION

(Must be completed by a California Licensed
Surveyor OR Civil Engineer)

On _____, I surveyed the highest point of the story poles and netting
Date

located at _____, Carmel-by-the-Sea, CA related to
Property Address/Location

plans submitted as part of design study/review application _____
Application No.

and have determined that the highest point of the story poles and netting is in
substantial compliance with the project plans submitted to the Community Planning and
Building Department.

I DECLARE UNDER PENALTY OF PERJURY THAT THE FOREGOING IS TRUE AND CORRECT.

Signature _____ Executed on _____
CA Licensed Surveyor OR Civil Engineer

Name _____ Phone No. (____) _____
Print Legibly

State License No. _____

Company _____

Please attach a photograph(s) demonstrating installation of the story poles and netting.